

## TEMPERATURE HiTESTER 3443, 3444, 3445

Environmental measuring instruments



# Quick and Easy temperature management

## Non-contact measurement

D-50.0 °C to 500 °C

## Use in tough environments

Dust / splash-proof design (IP54)

## RS-232C communication

For Personal Computer

The photograph is an **actual-size 3444**.



ISO 9001  
JMI-0216



ISO 14001  
JQA-E-90091



[www.hioki.com](http://www.hioki.com)

HIOKI company overview, new products, environmental considerations and other information are available on our website.



# The right tool for the job. Efficient

## Quickly measure and collect data

### ■ Ideal for daily temperature checks -- 3443 with integrated memory



- For temperature management according to ISO 14001 and energy conservation
- For food temperature control (HACCP)

The 3443 has a built-in memory that can store information about measured temperature and measurement date/time in 64 channels (maximum 130 data). It is also possible to add the **INTERFACE PACK 3909** later, allowing transfer of data to a computer. A dedicated software program ensures efficient management of periodic temperature measurement data.

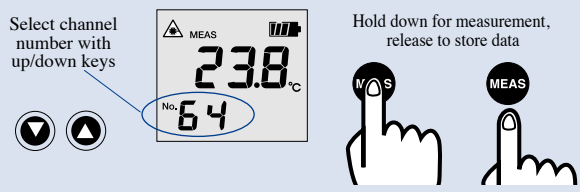

Select the appropriate channel number (1 - 64) according to the measurement point. While the MEAS key is pushed, measurement is carried out. When the key is released, the unit automatically stores the measured temperature as well as the time and date of measurement.



RS-232C  
INTERFACE

### ■ For temperature monitoring -- 3444 / 3445 with real-time output



- 3444 is great for checking the temperature of electrical equipment while keeping a safe distance
- 3445 lets you perform easy spot checks to detect parts warming

The 3444 has a long and narrow focus, whereas the 3445 features a short focus for close-range spot measurements. Using the optional **INTERFACE PACK 3909**, measurement data can be sent in real time to a level recorder or a computer. This is especially useful for long-term monitoring of temperature changes and for reliable detection of problem situations.

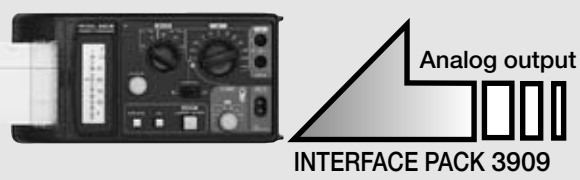

RS-232C  
INTERFACE

### ■ Major differences between 3 models

Function	3443	3444	3445
Data memory (130 points)	○		
MAX./MIN. indication		○	○
Memory dump to printer	○		
Analog output		○	○
RS-232C interface	○	○	○

Functions shown in   require the optional 3909.

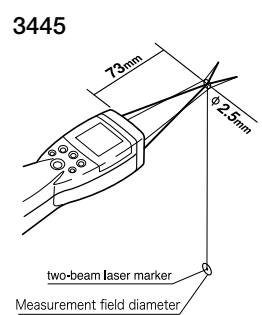
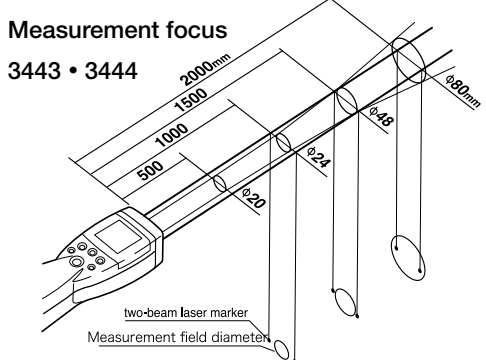

# temperature control made easy.

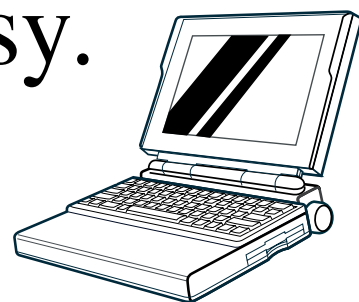

Dedicated software (option) allows

## Data analysis and management

### Channel (management number) table

For each channel, a title and operator name be entered. Maximum, minimum, and average values for collected temperature data can be shown.

No.	Title	Start Time	Stop Time	Data Num.	Max[C]	Min[C]	Ave[C]	Meas.
1	Fan motor1	98/10/28 13:36	98/10/30 13:37	9	28.7	27.9	28.2	T. Sato
2	Fan motor2	98/10/28 15:05	98/10/30 15:07	7	24.6	24.3	24.5	T. Sato
3	Fan motor3	98/10/29 15:10	98/10/30 15:11	4	25.5	25.2	25.4	T. Sato
4	Fan motor4	98/10/29 15:12	98/10/30 15:13	4	25.8	24.5	25.4	T. Sato
5	Braker1	98/10/29 15:20	98/10/30 15:21	4	41.4	41.0	41.2	T. Sato
6	Braker2	98/10/29 15:23	98/10/30 15:23	4	38.6	38.3	38.5	T. Sato
7	Braker3	98/10/27 15:30	98/10/30 15:30	14	49.5	47.8	48.7	T. Sato
8	Braker4	98/10/28 15:38	98/10/30 15:38	6	25.2	25.0	25.1	T. Sato
11	Braker5	98/10/28 13:36	98/10/30 13:37	9	29.7	27.9	28.2	T. Sato
12	Braker6	98/10/28 15:05	98/10/30 15:07	7	24.6	24.3	24.5	T. Sato

### Channel detail view

Shows all collected data for that channel. Entering an upper and lower limit for OK/NG evaluation is also possible.

No.	Date	Time	Data[C]	Unit
1	98/10/27	15:30	48.7	Hi
2	98/10/27	15:30	48.9	
3	98/10/27	15:30	49.1	
4	98/10/28	15:30	47.9	Lo
5	98/10/28	15:30	47.9	Lo
6	98/10/28	15:30	48.0	
7	98/10/28	15:30	49.2	Hi
8	98/10/28	15:30	49.3	Hi
9	98/10/28	15:30	49.5	Hi
10	98/10/28	15:30	49.1	
11	98/10/30	15:30	48.5	
12	98/10/30	15:30	48.6	

PACK 3909

### Current temperature indication

Read-in interval can be set in 1-second steps from 1 second to 60 minutes.

### Data history and compilation result

Up to 32,000 pieces of data can be acquired for each channel.

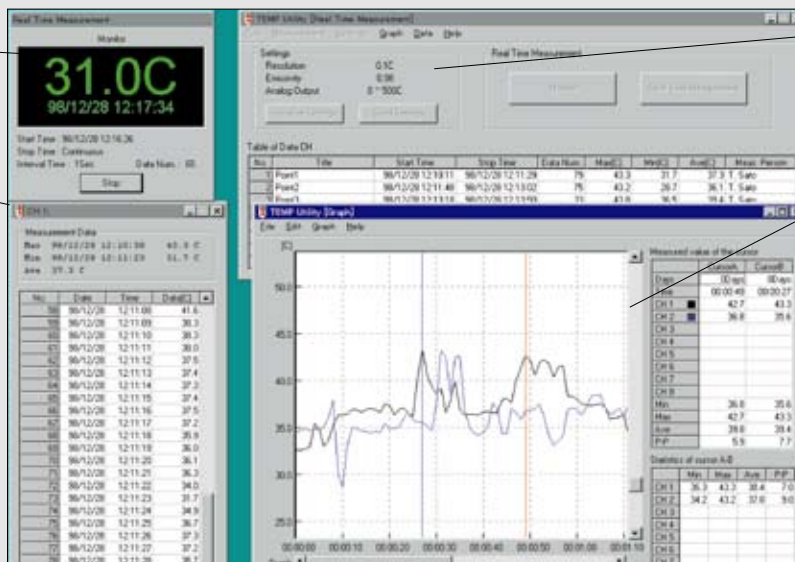

### Unit control settings

Emissivity, resolution, and full-scale range of analog output (3444/3445) can be set.

### Graph display (time-based)

Real-time indication of temperature data. Past data for up to 8 channels can also be shown as an overlay, in order to observe temperature fluctuations.

### Cursor range statistics

The maximum/minimum/average temperature fluctuation for a range between two cursors can be measured.

PACK 3909

## 3909 INTERFACE PACK (optional)

Supplied with dedicated software (TEMP utility) for data analysis / management and unit control

This option is compatible with all three models (3443/3444/3445). It allows connection to a computer or to a level recorder (3444/3445 only).

■ **Package contents:** modular cable (50 cm), expansion box, analog output cable (open-ended, 2 m). TEMP utility (Japanese/English version, 2 3.5-in floppy disks) ■ **TEMP utility specifications**

● **Operating system requirements:** Windows 95, Windows 98 or Windows NT 4.0 \*1 ● **Print functions:** data table or graph printout on A3, A4, B4, B5 size paper (portrait or landscape) ● **Other functions:** file import, file save (CSV format), graph image export to word processor, simultaneous read-in to spreadsheet software

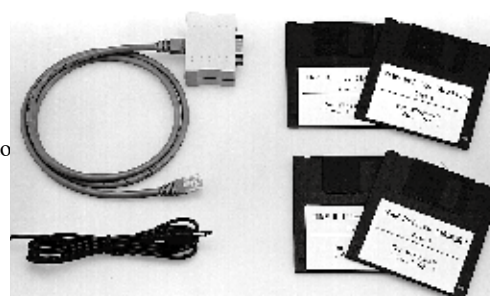

Note: The connection cable (for 3909 to Computer) is not supplied.  
Computer (3909 output) connector: D-sub 9 pin

\*1 Trademarks of Microsoft Corporation, USA.

■ **Common specifications** (accuracy at 23°C ±3°C, 55% rh, with emissivity ε = 1.0)

●**Measurement range:** -50.0 to 500.0°C ●**Display resolution:** 0.1°C (3444/3445 switchable between 0.1°C and 1°C) ●**Measurement accuracy:** ±1% rdg. (200.1 to 500.0°C), ±2°C (0.0 to 200.0°C), ±10% rdg. ±2°C (-50.0 to -0.1°C) ●**Repeatability:** ±0.5°C (0.0 to 500.0°C), ±1.0°C (-50.0 to -0.1°C) ●**Response time:** 1.6 seconds (95% response at 0.1°C resolution), 0.7 seconds (95% response at 1°C resolution) ●**Sampling rate:** 0.8 seconds/measurement ●**Measurement field diameter:** 3443/3444, Ø24 mm at 1 m; 3445, Ø2.5 mm at 73mm ●**Detector element:** thermopile ●**Optical lens:** silicon ●**Measurement wavelength:** 8 to 16 μm ●**Targeting:** two-beam laser marker class 2 ●**Emissivity correction:** ε= 0.10 to 1.00 (0.01 steps) ●**Ancillary functions:** auto power save (15 seconds, can be canceled); low battery warning, measurement value auto-hold (3443 only), data memory (130 points, 3443 only), data memory dump to printer (3443 only; requires 3909), MAX./MIN. display (3444/3445 only), analog output (3444/3445 only; requires 3909), RS-232C output (requires 3909) ●**Ambient conditions for use:** 0 to 40°C, 35 to 85% rh (no condensation) ●**Ambient conditions for storage:** -20 to 55°C (no condensation) ●**Compatible standards:** EMC EN61326-1:1997+A1:1998, external protection EN60529:1991 [IP54] ●**Power source:** layer 6F22 manganese battery × 1 or AC adapter ●**Current consumption:** max. 252 mVA (light on), max. 90mVA (light off) ●**Continuous operating time:** max. 20 hours (light on), max. 50 hours (light off) ●**Dimensions and mass:** approx. 47 W × 200 H × 48 D mm, approx. 280 g (including battery) ●**Accessories:** CARRYING CASE, HAND STRAP, screwdriver for battery compartment cover

■ **Related Products**

**Instantaneous Imaging**  
of 64-point Temperature Distributions



2D THERMO HITESTER 3460 performs 2-dimensional temperature measurement with a newly developed thermopile array sensor (8×8 elements), dividing the measured part of the visual image area into 64 boxes and displaying the temperature with a high-speed response of approximately 0.5 seconds.

**2D THERMO HITESTER 3460-50**  
Please see the catalog for details of the respective products

**Basic convenience at a very attractive price**  
Non-contact temperature measurement entry models



Long-range, narrow field (Ø72mm at 1m) model **3415-01** (with 2-beam laser marker) and model **3418** (without marker). Short-range spot measurement (Ø2.5 mm at 3 cm) model **3416-01**. All are easy to operate and provide temperature readings at the touch of a button. Measurement range is -50 to +500°C, with a resolution of 1°C, and measurement time is 1.5 seconds.

**TEMPERATURE HITESTER 3415-01 / 3416-01 / 3418**

- TEMPERATURE HITESTER 3443** ..... With integrated memory, narrow field measurement type (Ø24mm at 1m)  
**TEMPERATURE HITESTER 3444** ..... With real-time output, narrow field measurement type (Ø24mm at 1m)  
**TEMPERATURE HITESTER 3445** ..... With real-time output, fine surface measurement (Ø2.5mm at 73mm)  
 (All include CARRYING CASE, HAND STRAP)

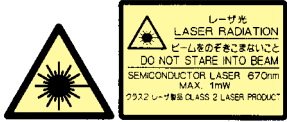

**Warning on use of laser products**  
The 3443/3444/3445 is labeled as shown above. Follow the warnings on the label when operating.



- Options**
- INTERFACE PACK 3909**
  - RS-232C CABLE 9637** (Dsub 9 pin-Dsub 9 pin, cross, 1.8 m)
  - AC ADAPTER** (3909 required)
  - BLACK BODY TAPE** (50mm × 10m, 1 roll) Withstands 180°C
  - BLACK BODY SPRAY** (180ml) Withstands 550°C
- \* Used for accurate determination of the temperature of a gloss metal object of low emissivity (ε), or for determining the emissivity.  
The thermal emissivity is the ratio between the amount of energy (the theoretical maximum) which would be emitted by a black body(ε=1) at the same temperature.

HIOKI

HIOKI E. E. CORPORATION

**HEAD OFFICE :**  
81 Koizumi, Ueda, Nagano, 386-1192, Japan  
TEL +81-268-28-0562 / FAX +81-268-28-0568  
E-mail: os-com@hioki.co.jp

**HIOKI USA CORPORATION :**  
6 Corporate Drive, Cranbury, NJ 08512 USA  
TEL +1-609-409-9109 / FAX +1-609-409-9108  
E-mail: hioki@hiokiusa.com

**HIOKI (Shanghai) Sales & Trading Co., Ltd. :**  
1904 Shanghai Times Square Office, 93 Huai Hai Zhong Road  
Shanghai, P.R.China POSTCODE: 200021  
TEL +86-21-6391-0090/0092 FAX +86-21-6391-0360  
E-mail: info-sh@hioki.cn

**Beijing Office :**  
A-2602 Freetown, 58 Dong San Huan Nan Road  
Beijing, P.R.China POSTCODE: 100022  
TEL +86-10-5867-4080/4081 FAX +86-10-5867-4090  
E-mail: info-bj@hioki.cn

**Guangzhou Office :**  
Room 303, Profit Plaza, No.76, West Huangpu Road  
Guangzhou, P.R.China POSTCODE: 510623  
TEL +86-20-38392673/2676 FAX +86-20-38392679  
E-mail: info-gz@hioki.cn

DISTRIBUTED BY

FINAL TEST<sup>™</sup>

Venta de Instrumentos de Prueba y Medición

**www.finaltest.com.mx**  
Calle del Ebano #16625  
Tijuana B.C. Mexico  
Tel. (664)681-1130  
Tel. 01800 027-4848  
ventas@final-test.net